

# **GREAT DESIGNS IN STEEL**

**Presentations will be available for  
download on SMDI's website on  
Wednesday, May 22**

# GREAT DESIGNS IN **STEEL**

## NEW ADVANCEMENTS IN ROBOTIC LASER CUTTING

Christon Manzella  
Shape Process Automation

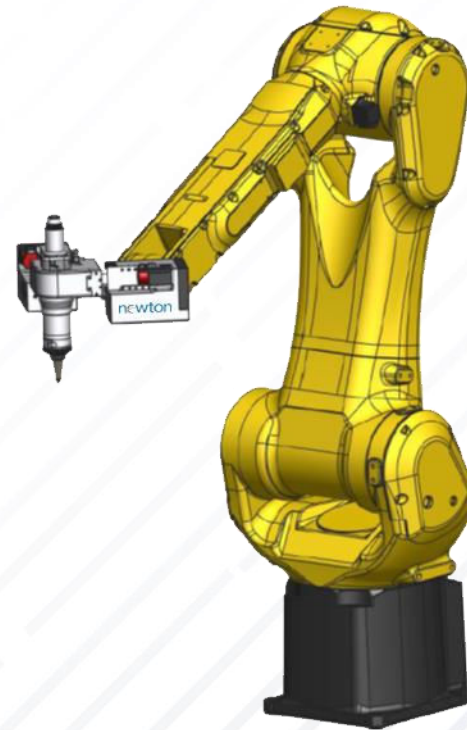

# ROBOTIC CUTTING

Explore robotic laser cutting and automation as a means to reduce manufacturing cost of UHSS parts

Labor

OEE – Overall Equipment Effectiveness

Increase Cpk

Floor Space

Process Advancements

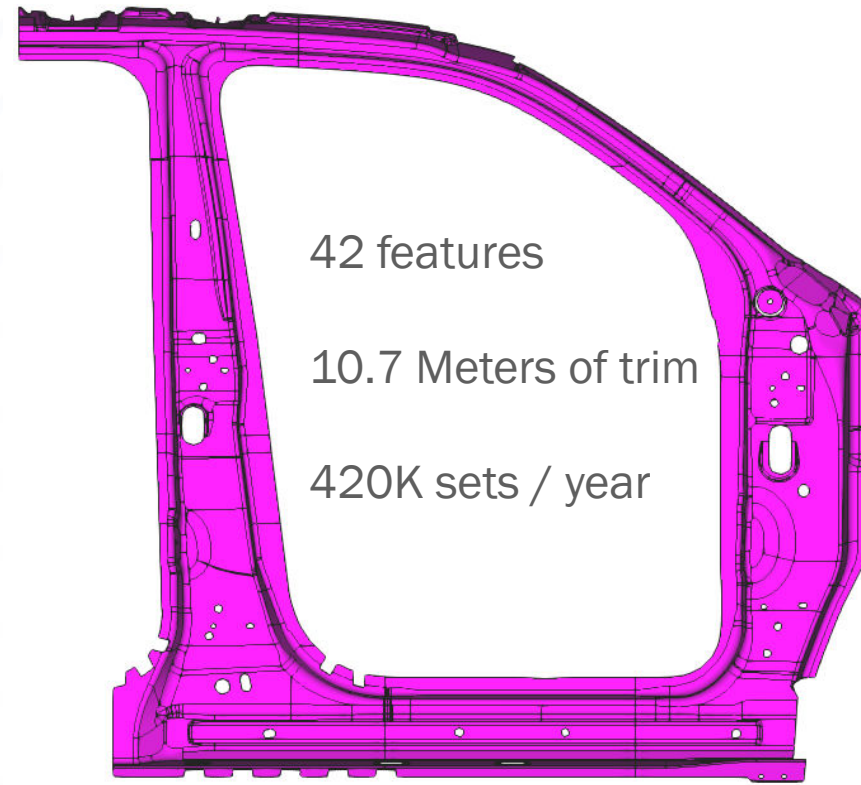

## RAM 1500



# TRADITIONAL CUTTING MACHINE

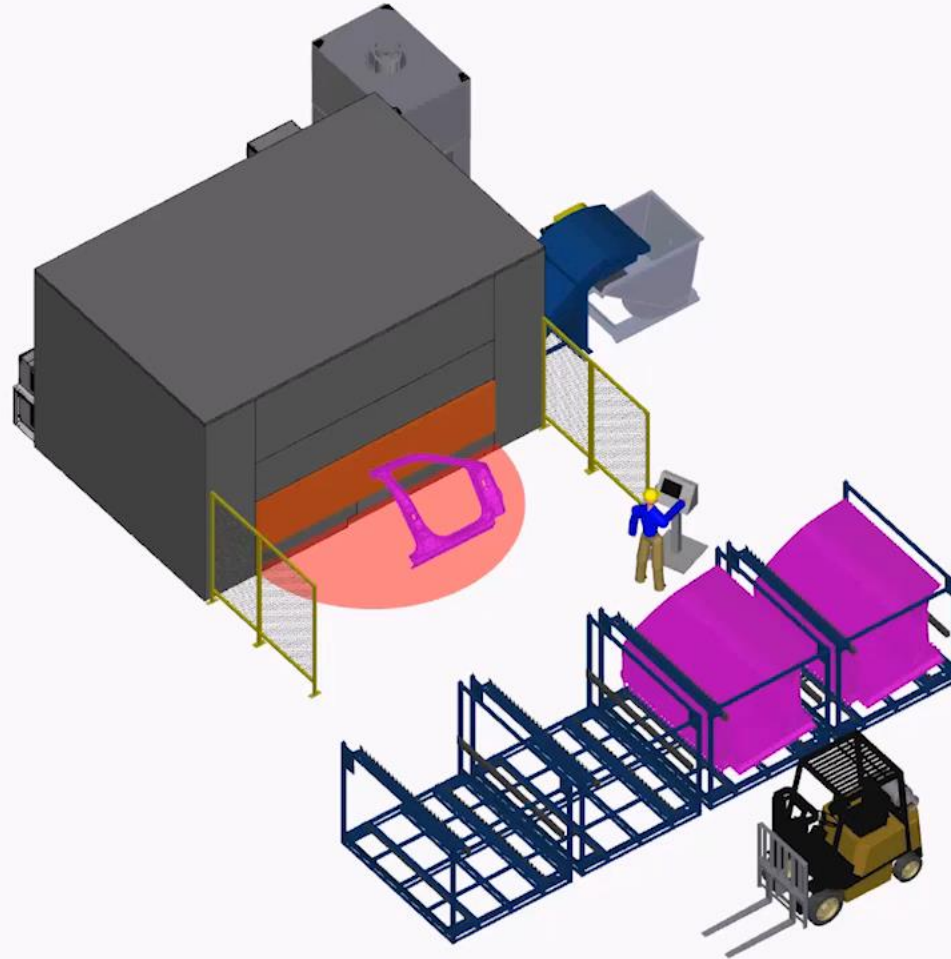

0.000 sec



# TRADITIONAL FLOOR SPACE, LABOR, FIXTURES

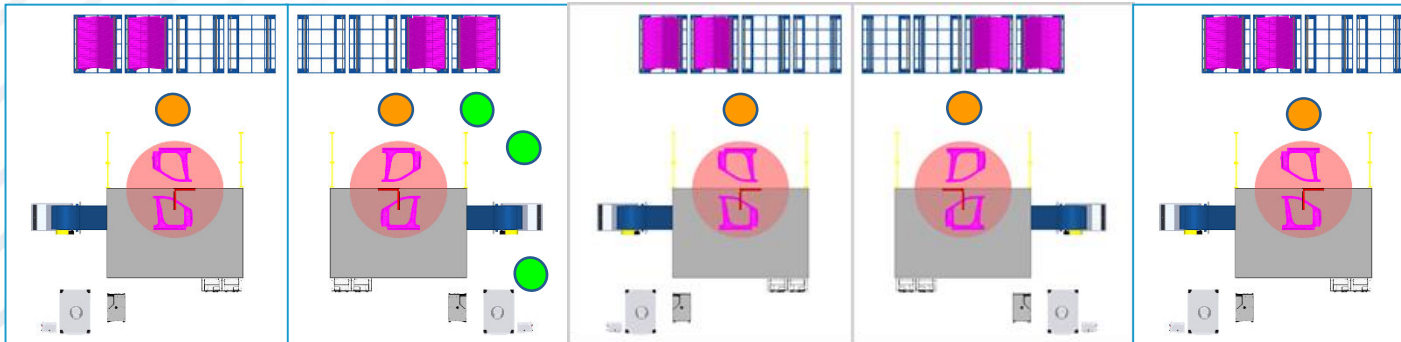
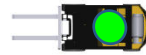
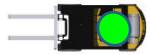
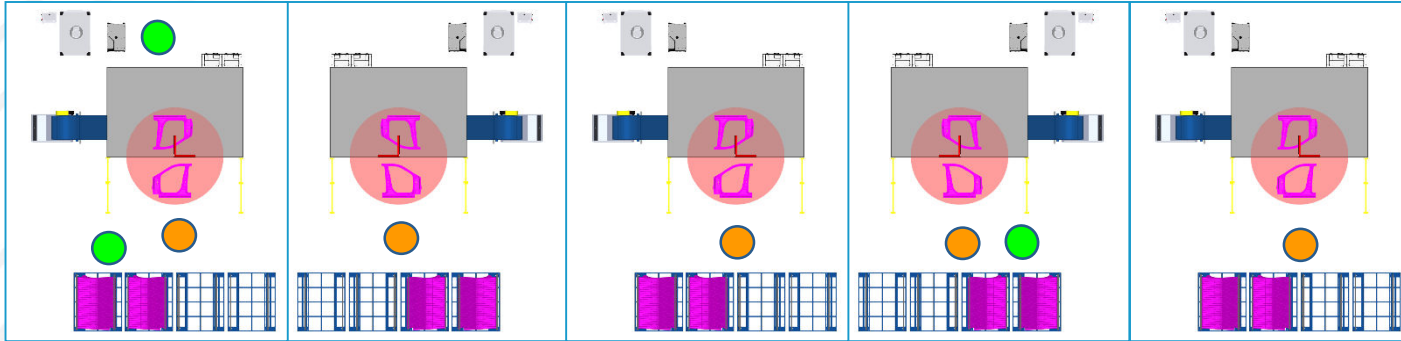

Item	Island
Square Foot	20,000
Direct Labor	10 ●
Indirect Labor	
Forklift Drivers	2 ●
Programmer	2 ●
Maintenance	2 ●
Quality	2 ●
# of fixtures	
Left hand	10 ●
Right hand	10 ●

# NEW ROBOTIC CUTTING

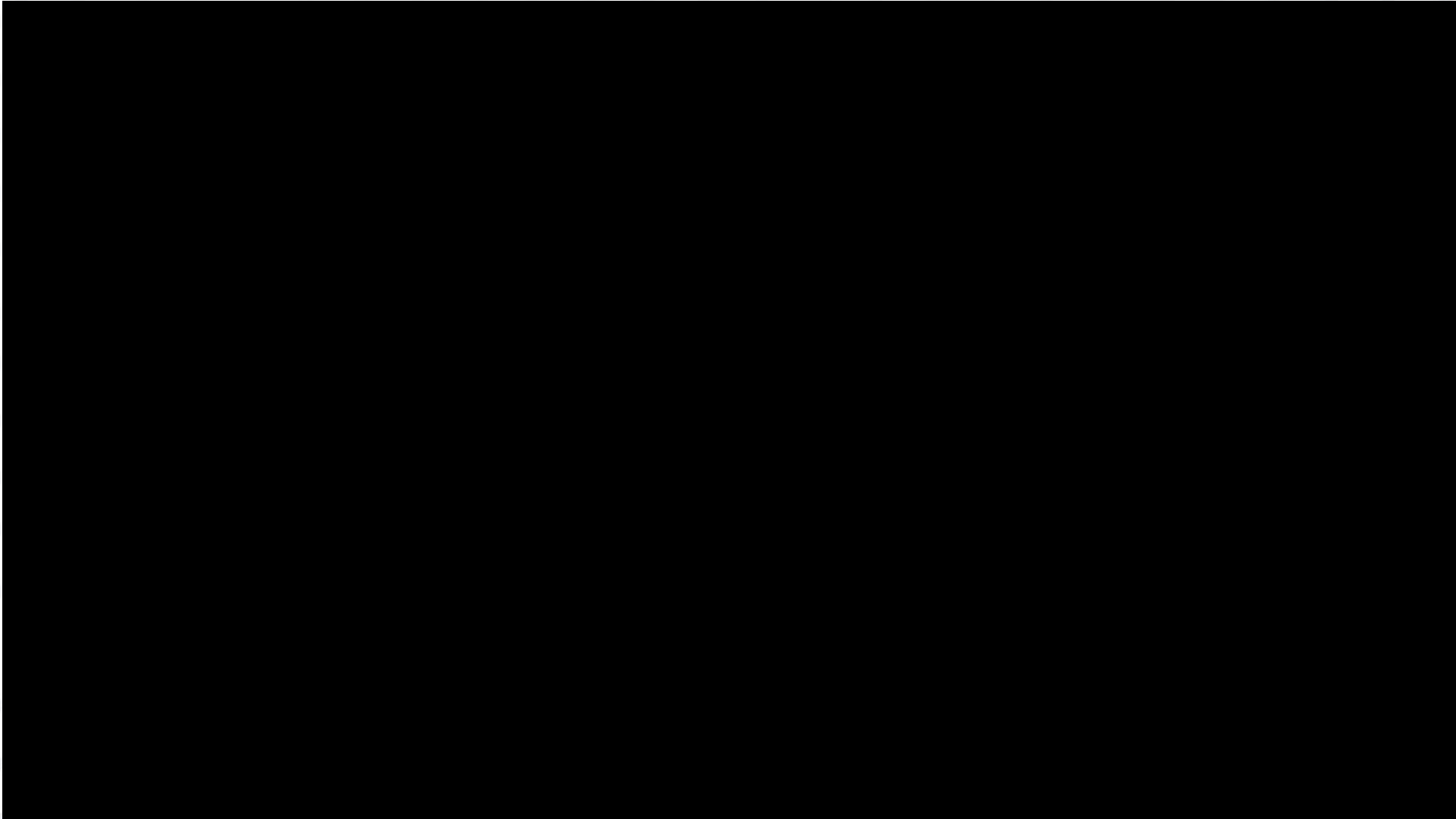

# ROBOTIC CUTTING FLOOR SPACE, LABOR, FIXTURES

**Savings:**

- Floor space: 70%
- Direct labor: 100%
- Indirect labor: 50%
- Fixtures: 80%

Item	Traditional	Robotic
Square Foot	20,160	6,050
Direct Labor	10	0
Indirect Labor		
Forklift Drivers	2	1
Programmer	2	1
Maintenance	2	1
Quality	2	1
# of fixtures		
Left hand	10	2
Right hand	10	2

# OEE - # OF PART PATHS

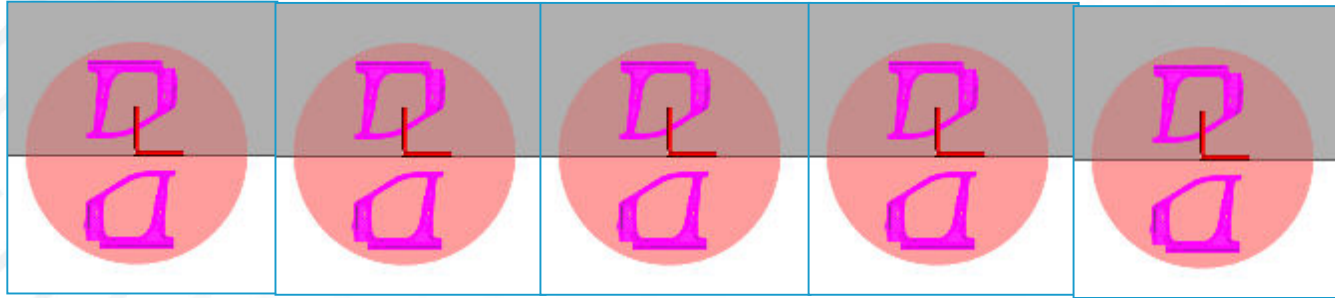

Traditional

10

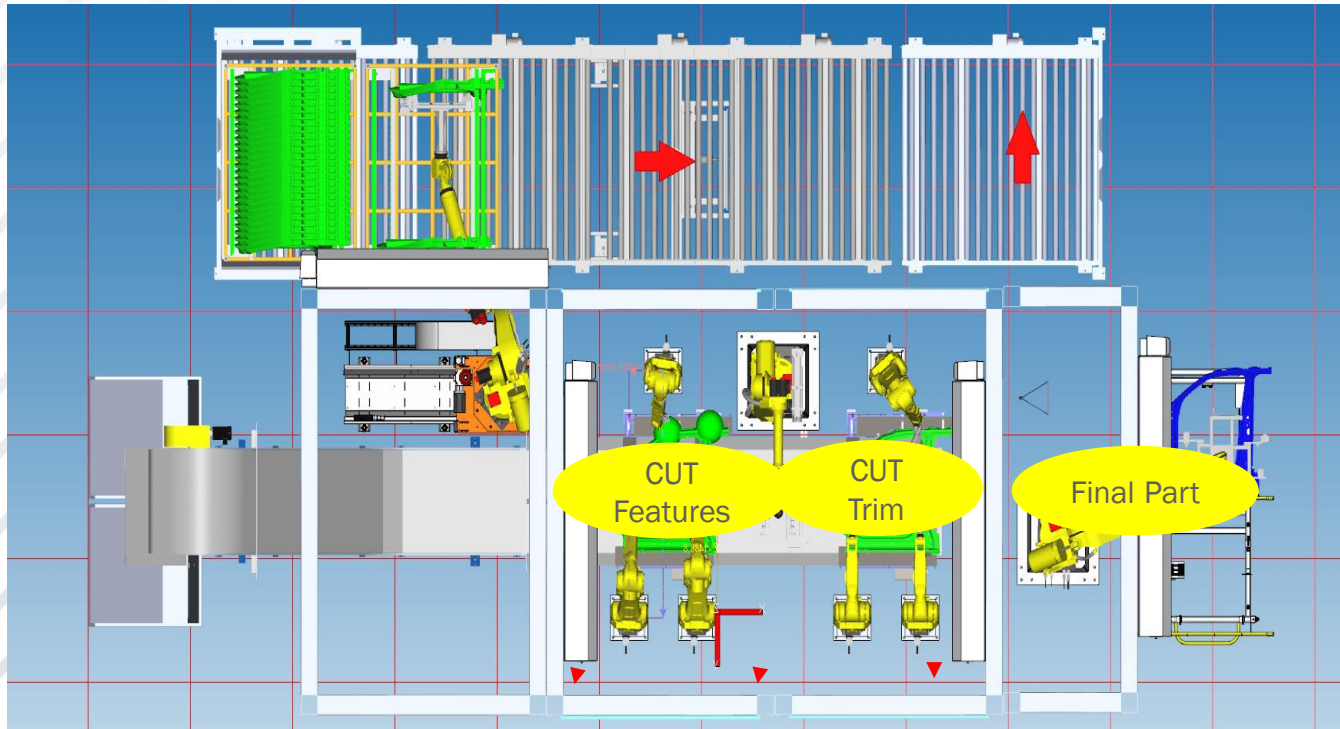

Robotic

1

Repeatability  
High Cpk



OEE



# NEW CUTTING TECHNOLOGY

GDIS

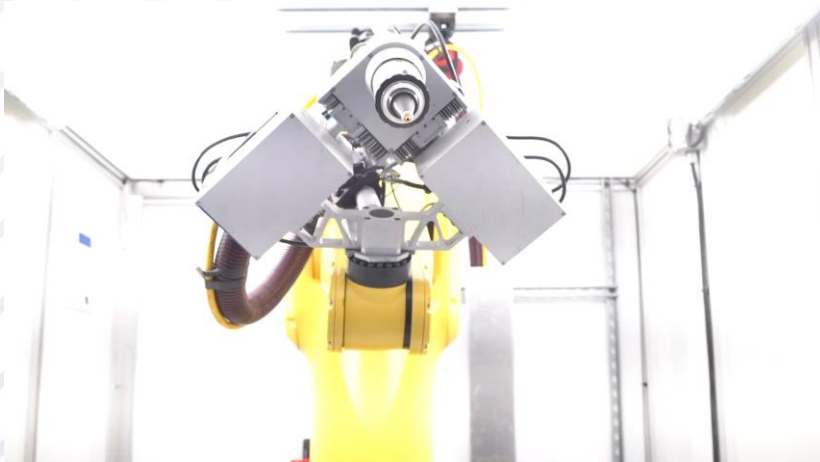
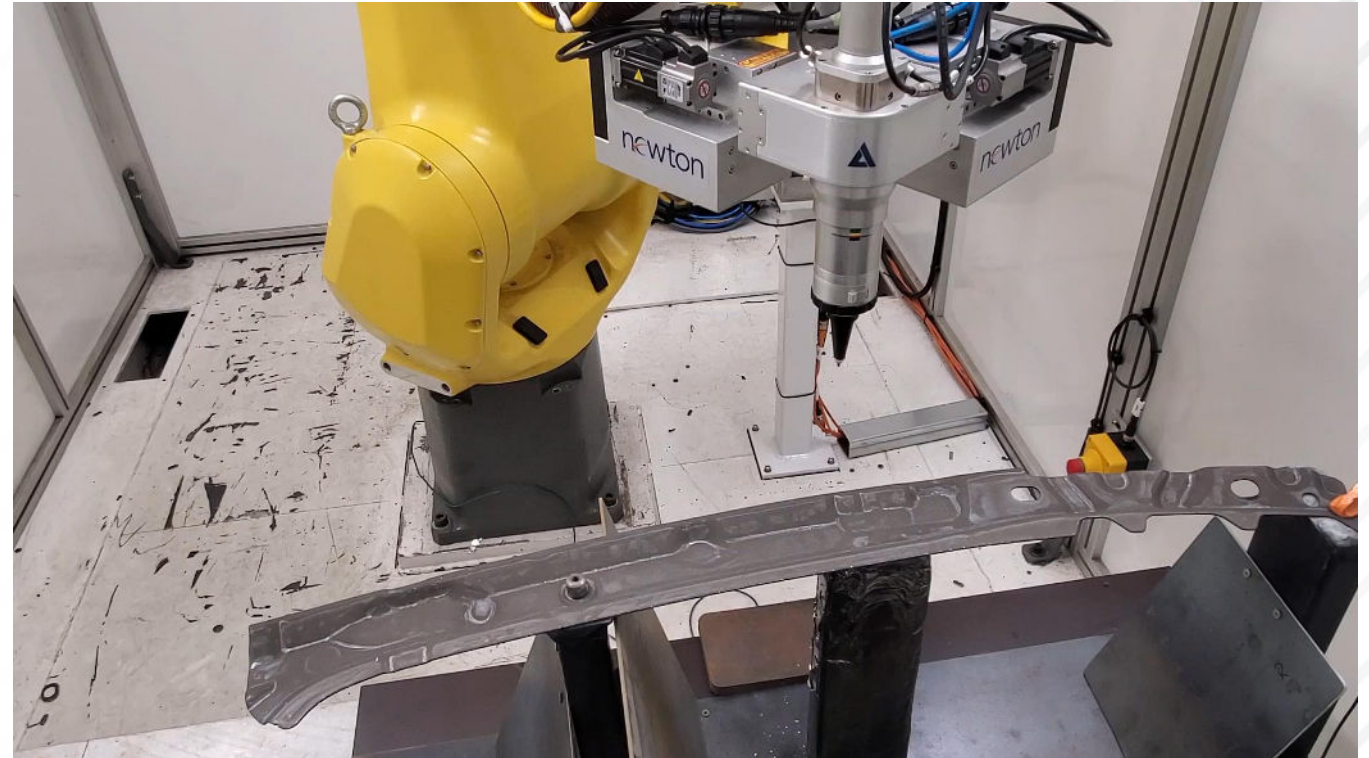

newton

# NEW ROBOTIC CUTTING



Robot Articulation



newton

Feature	Size	Robot Cut Time	newton Cut Time	Cutting time REDUCTION
Circle	15	1.3	0.39	70%
Slot	10x20	1.8	0.45	75%
Rectangle	10x20	2.3	0.71	69%
Hex	15	3.5	0.98	72%





# NEW ROBOTIC CUTTING



Robot Articulation



newton

Feature	Size	Robot Tolerance	newton Tolerance	Tolerance Improvement
Circle	15	+/- 0.20	+/- 0.10	50%
Slot	10x20	+/- 0.20	+/- 0.10	50%
Rectangle	10x20	+/- 0.25	+/- 0.10	60%
Hex	15	+/- 0.25	+/- 0.10	60%

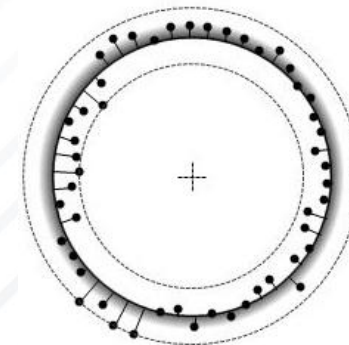

# POTENTIAL VALUE ADD PROCESSES

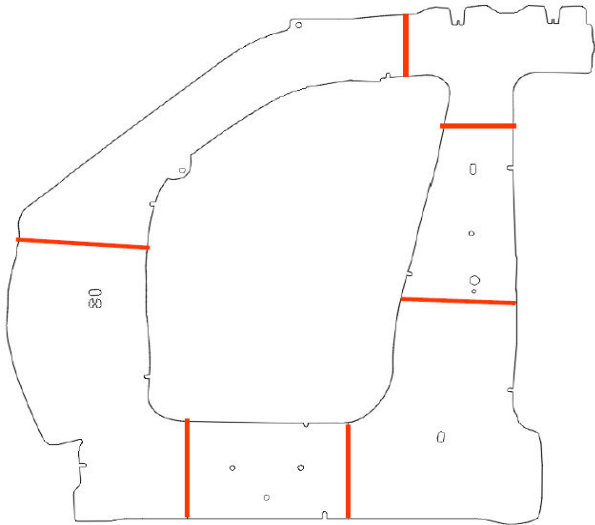

Predeveloped  
Blank provider

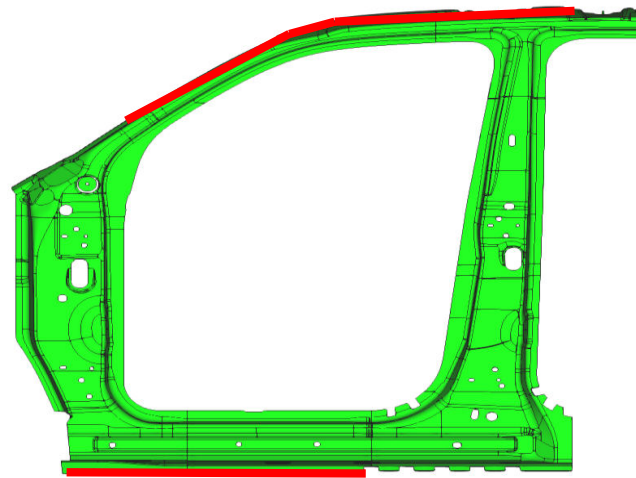

Near net Shape  
Blank Provider Hot Stamper

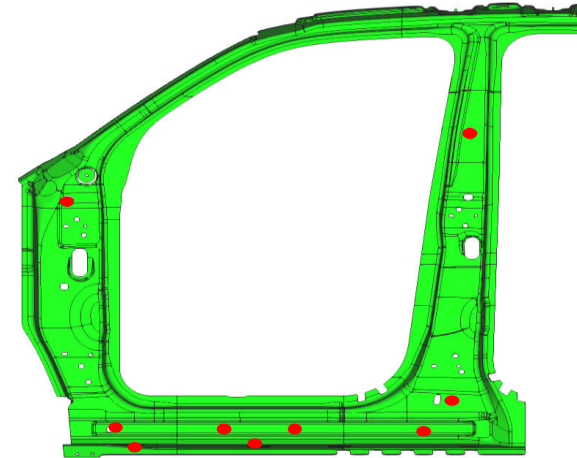

In-Die Pierce  
Hot Stamper

Decrease laser cycle time with complementary technologies

OEM, Stamper, and Blank provider collaboration



# NEW TECHNOLOGY REDUCES PROGRAM COSTS

Island of automation vs Inline automation	Floor space	Labor	Robot Reduction due to new technologies
Inline automated robotic laser cutting	16 robots		
NEWTON cutting technology	12 robots		25%
Near Net shape	10 robots		38%
Predevelop holes, In-die pierce	8 robots		50%

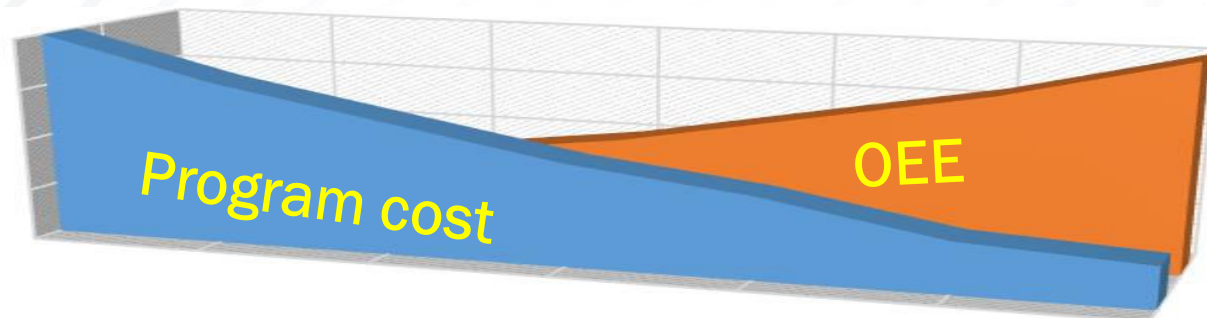

Thank you!

Questions?

# **GREAT DESIGNS IN STEEL**

**Presentations will be available for  
download on SMDI's website on  
Wednesday, May 22**